

FS100 Installation For The MF100\MG100\ML100 Flowmeters

1. Relieve the pressure and drain the line prior to installation. Determine the location of the FS100 on the outside of the pipe. The distance (A) between the bolt hole and the centerline of the ell is indicated on the table below. The centerline of the FS100 must be parallel to the centerline of the pipe.

METER SIZE	A	B	C
6"	20 5/8	2 5/8	17/32
8"	22 3/4	3 1/2	17/32
10"	24 7/8	4 3/8	21/32
12"	27	5 1/4	21/32

2. Establish the centerline of the pipe by a centering tool. Mark the pipe for the bolt location (see B dimension in the table above).

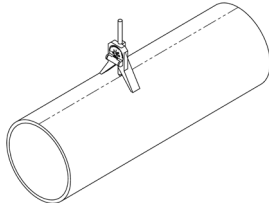

3. Drill a hole (see C dimension in the table). Remove the meter from the line.

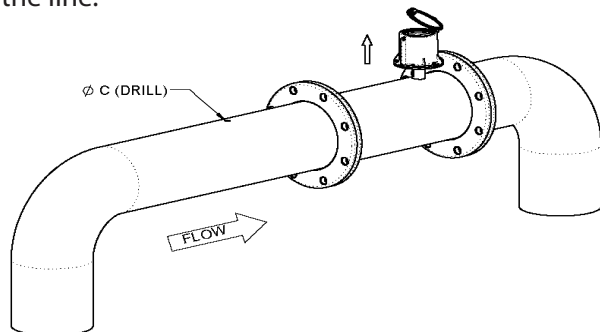

5. Secure the FS100 with the bolt, washer and o-ring supplied with the FS100. Place sealing rubber washer and the o-ring under bolt against the outside of the pipe. Secure the bolt to hold the FS100 to the pipe. Apply Loctite® anti-seize C5-A, or other appropriate lubricant, to the bolt prior to installation to ensure the bolt and nut do not seize up prior to creating an effective seal.

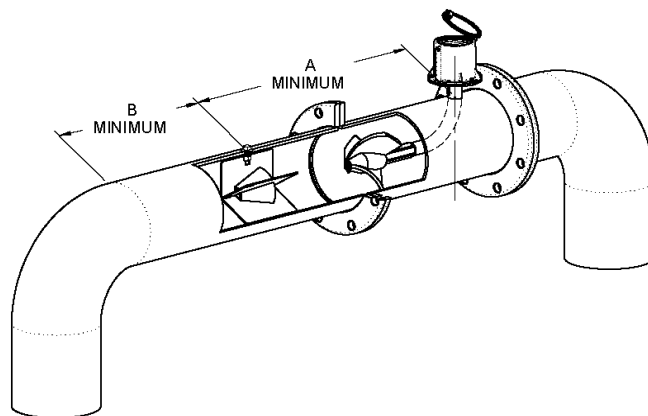
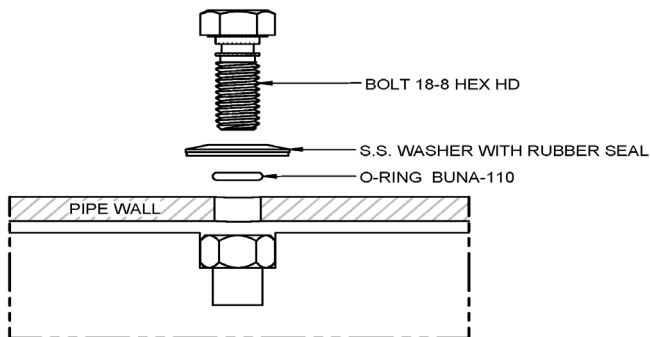

4. Insert the FS100 into the pipe.

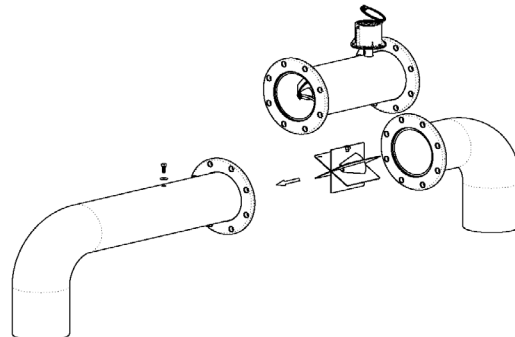

6. Reinstall the meter.

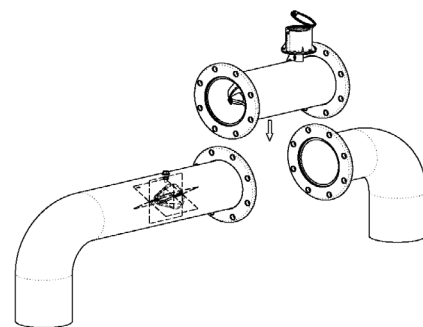

NOTE: It is advised the installer not use air guns or impact wrenches to tighten the bolt as it may damage the FS100 flowstraightener.

FS100 Installation For The M0300\M0300F Flowmeter

See the template supplied with the M0300F for flowmeter installation instructions.

1. Relieve the pressure and drain the line prior to installation. Determine the location of the FS100 on the outside of the pipe. The distance (A) between the bolt hole and the centerline of the ell is indicated on the table below. The centerline of the FS100 must be parallel to the centerline of the pipe.

METER SIZE	A	B	C
6"	20 5/8	2 5/8	17/32
8"	22 3/4	3 1/2	17/32

2. Establish the centerline of the pipe by a centering tool. Mark the pipe for the bolt location (see B dimension in the table above).

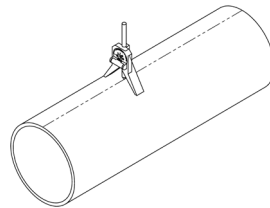

3. Drill a hole (see C dimension in the table). Break line at a flange or cut pipe in a portion near the installation location of the FS100.

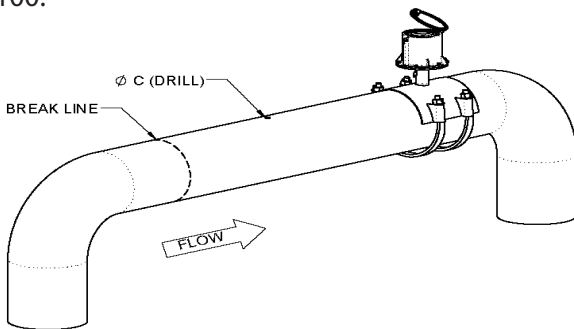

4. Insert the FS100 into the pipe.

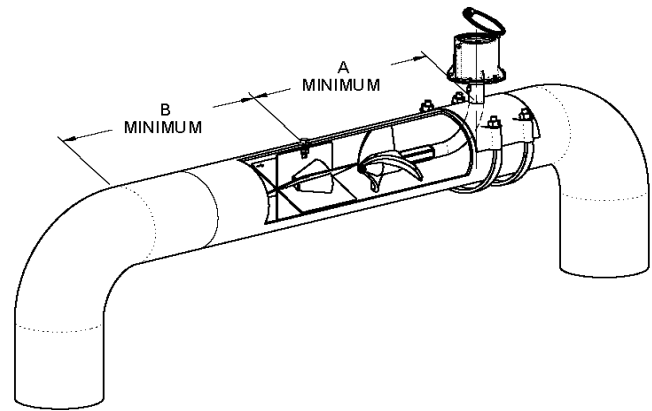

5. Secure the FS100 with the bolt, washer and o-ring supplied with the FS100. Place sealing rubber washer and the o-ring under bolt against the outside of the pipe. Secure the bolt to hold the FS100 to the pipe. Apply Loctite® anti-seize C5-A, or other appropriate lubricant, to the bolt prior to installation to ensure the bolt and nut do not seize up prior to creating an effective seal.

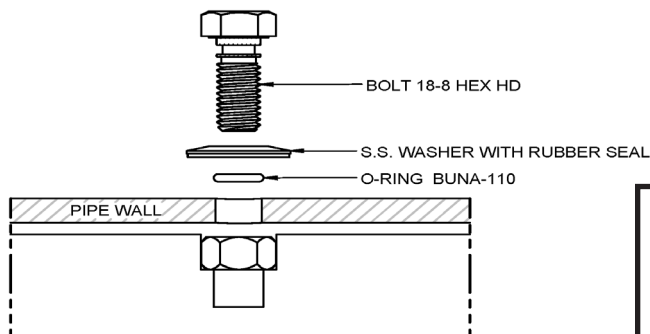

6. Close the line at the flange or repair the break.

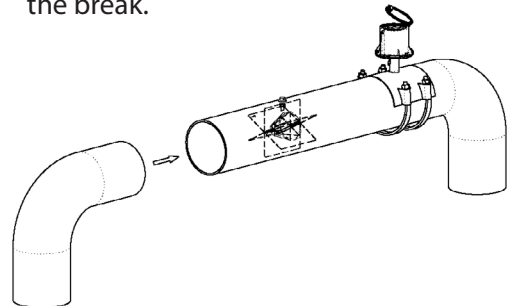

NOTE: It is advised the installer not use air guns or impact wrenches to tighten the bolt as it may damage the FS100 flowstraightener.